

For Residential and Commercial Applications

Job Name		Engineer / Architect	
Job Location		Wholesaler	
Submittal Date		Contractor	

S15-10 Loose Key Handle

Use: For use with BrassCraft® supply stops with loose key stems.

Design Features:

- **Large loose key handle** provides a secure grip for trouble-free on/off operation
- **Removable loose key handle** helps protect against accidental stop operation during rough-ins and general use

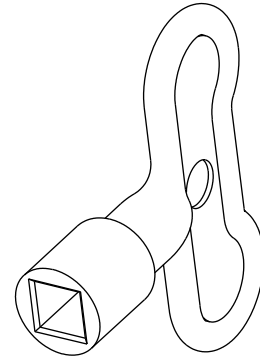

MATERIAL SPECIFICATIONS	
Loose Key Handle	Zinc, die cast

Part Listing:

- S15-10 C Loose key handle
- S15-10 CB Loose key handle, bulk
- S15-10 CD Loose key handle, carded

PART DIMENSIONS (Inches)			
Model	DIM. A	DIM. B	DIM. C
S15-10	1.75	1.94	.27

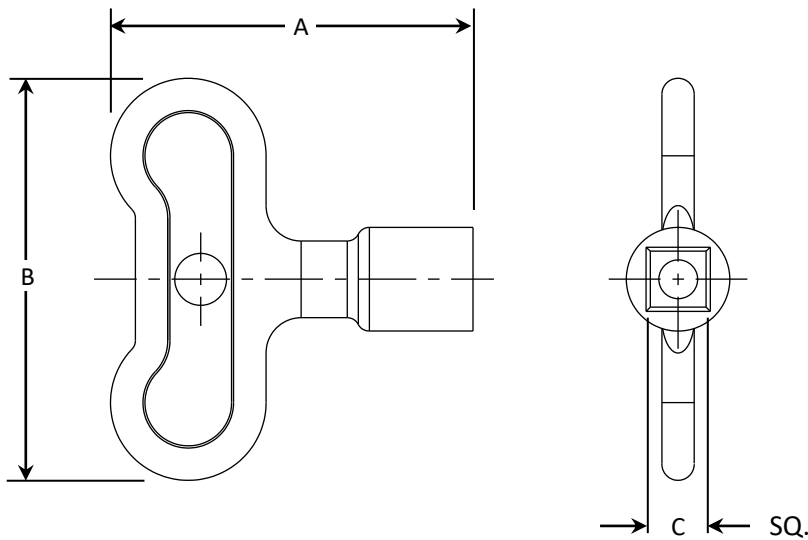

This specification and all information contained herein is the confidential and exclusive property of Brasscraft Manufacturing Co., and shall not be disclosed to others without the written consent of Brasscraft Mfg. Co. This specification must be returned to Brasscraft Mfg. Co. if requested.